



INSTALLATION INSTRUCTIONS

Accessory
FENDER C PANEL
P/N 08F78-MKJ-D00

Application
CB1000RA

Publication No.
MII
Issue Date
January 2018

Honda Dealer: Please give a copy of these instructions to your customer.

PARTS LIST

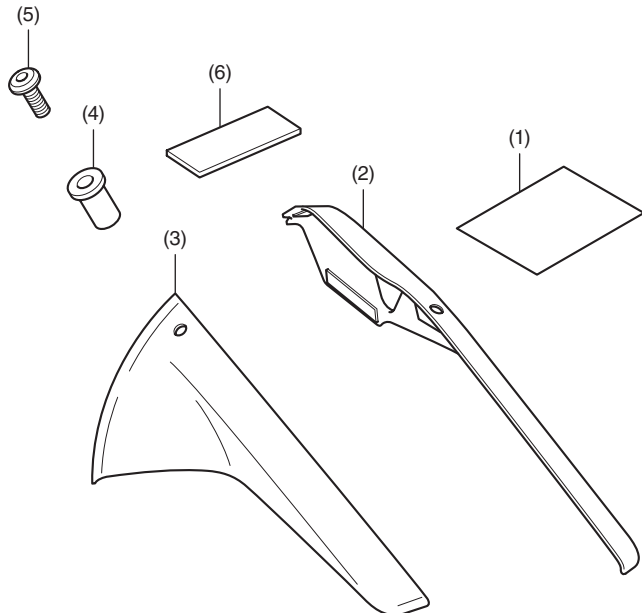

No.	Description	Qty
(1)	URL paper	1
(2)	Right fender C panel	1
(3)	Left fender C panel	1
(4)	Well nut	2
(5)	5 mm bolt	2
(6)	Double-side adhesive tape	1

TOOLS AND SUPPLIES REQUIRED

- Hex wrench (3 mm)
- Electric drill
- Drill bit (10 mm)
- Scale
- Scissors
- Isopropyl alcohol
- Shop towel
- Torque wrench

TORQUE CHART

Tighten all screws, bolts, and nuts to their specified torque values. Refer to the Service Manual for the torque values of the removed parts.

Item	N·m	kgf·m	lbf·ft
5 mm bolt	0.4	0.04	0.3

INSTALLATION

▲ CAUTION

- To prevent burns, allow the engine, exhaust system, radiator, etc., to cool before installing the accessory.

NOTE:

- Heat the bonding surfaces with a hair dryer if the ambient air temperature is below 70°F (21°C).
- The adhesive reaches full strength in 72 hours. Wait at least 24 hours before riding your motorcycle.

1. Remove the screw as shown.

<Right side>

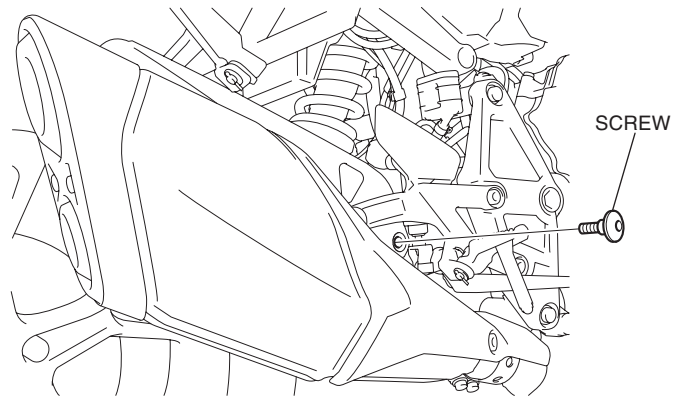

2. Remove the clip as shown.

<Left side>

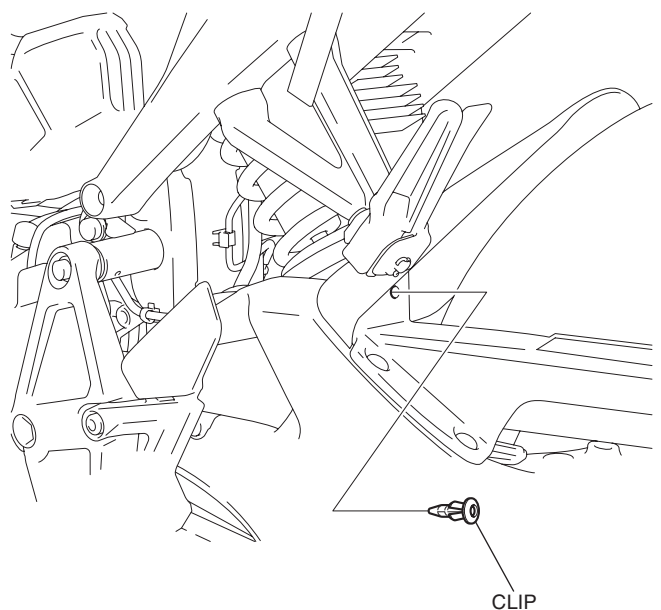

3. Remove the rear fender C as shown.

<Left side>

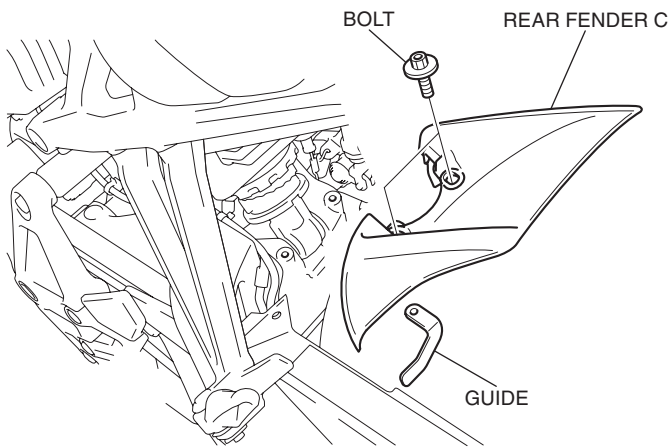

4. Drill at the marked points of the rear fender C as shown.

- Remove the any burrs from the edge of the hole.

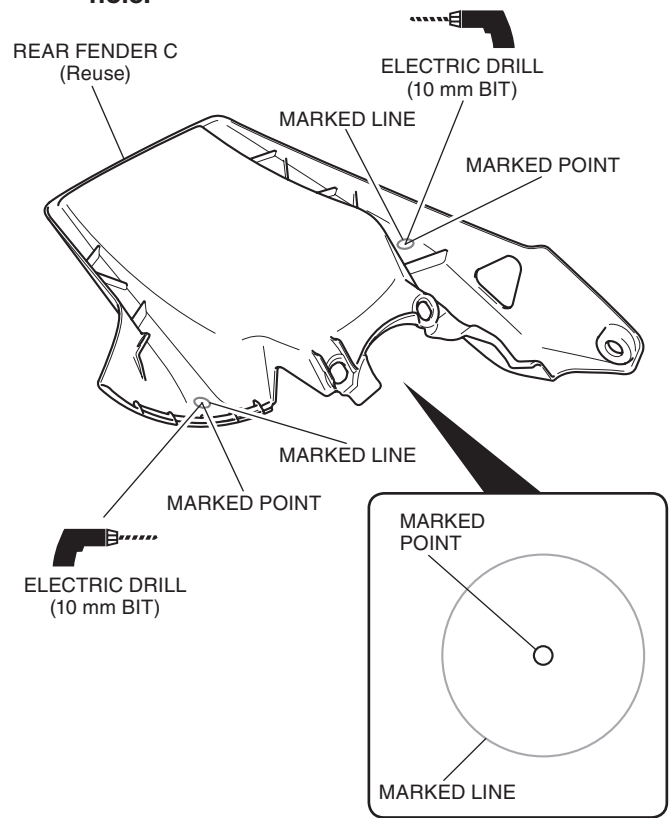

5. Clean the surface of the area shown using an isopropyl alcohol.

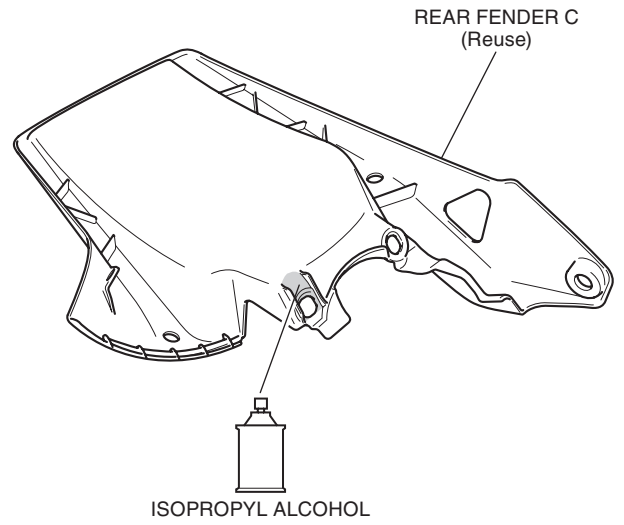

6. Clean the surface of the area shown using an isopropyl alcohol.

<Left side>

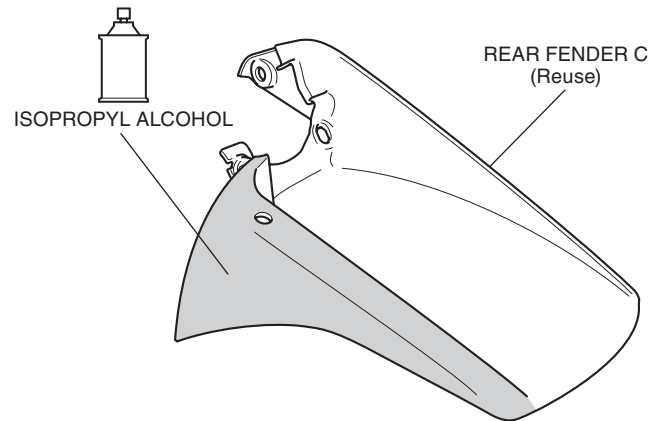

<Right side>

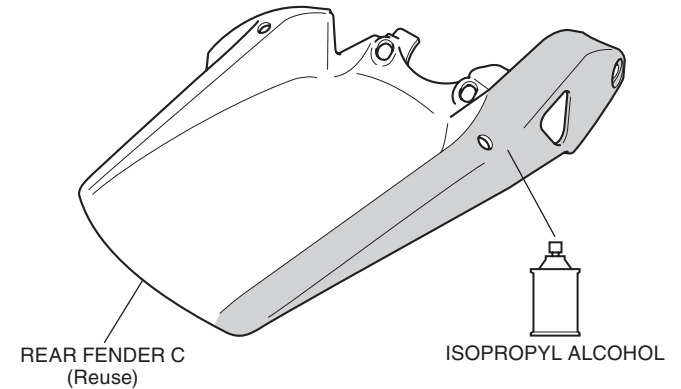

7. Install the well nuts as shown.

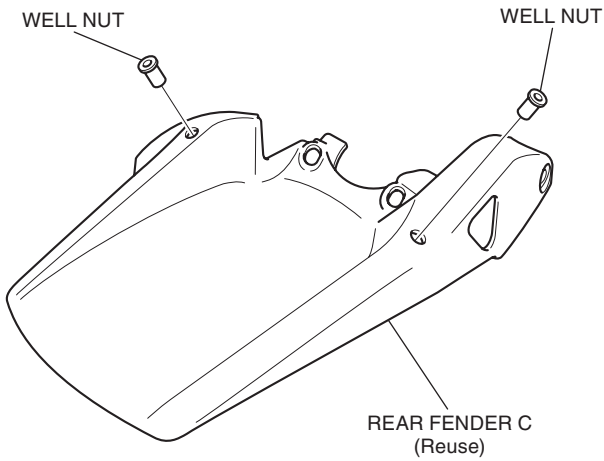

8. Peel off the adhesive backing on the left fender C panel as shown.

ADHESIVE BACKING
Peel back leaving a little adhered.

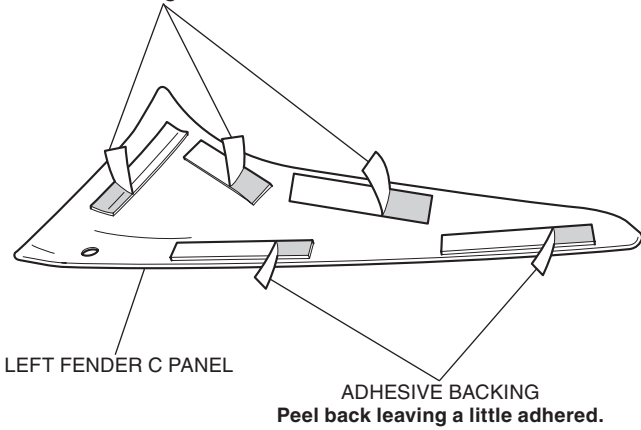

9. Attach the left fender C panel as shown.

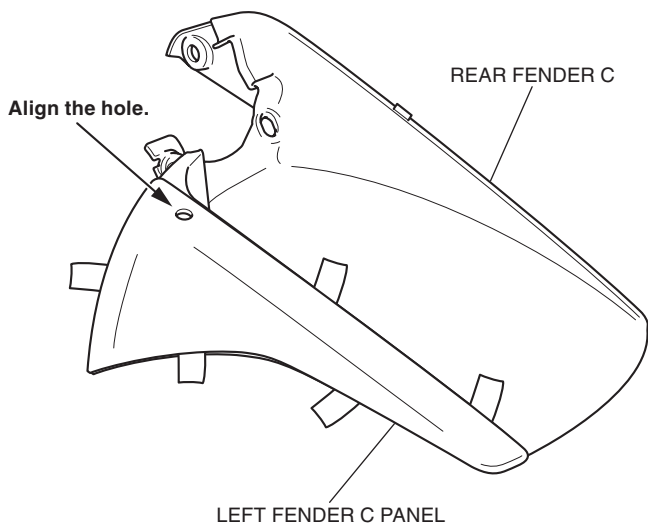

10. Remove the adhesive backing as shown.

ADHESIVE BACKING
Pull out while pressing on the left fender C panel.

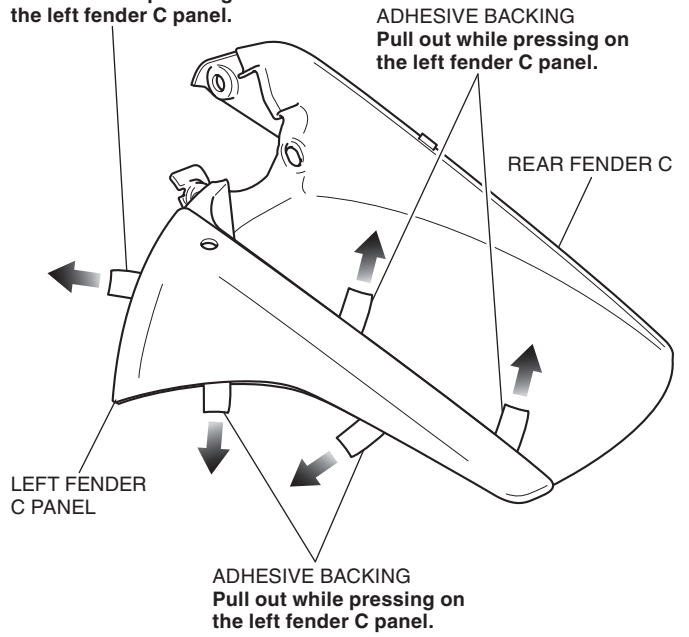

11. Apply adequate pressure to the attached left fender C panel.

12. Attach the right fender C panel in the same manner as the left side.

13. Install the 5 mm bolts as shown.

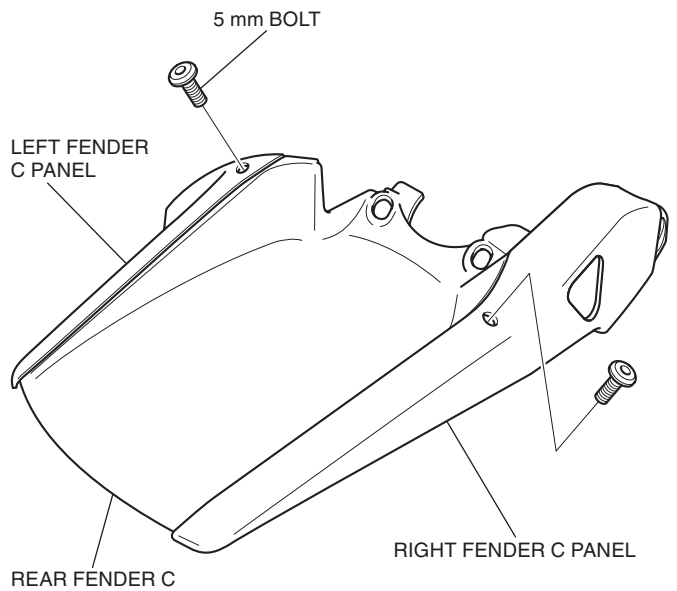

14. Cut the double-side adhesive tape as shown.

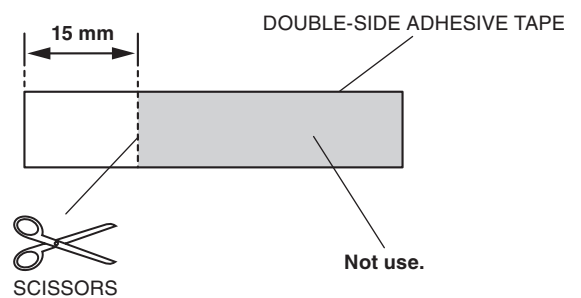

15. Clean the surface of the area shown using an isopropyl alcohol.

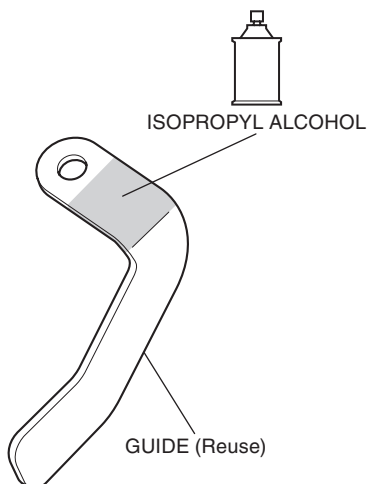

16. Attach the cut double-side adhesive tape as shown.

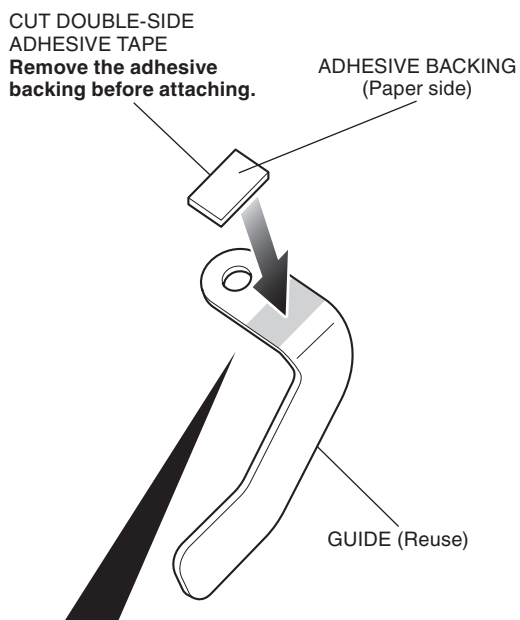

Attach the cut double-side adhesive tape with dimensions as shown.

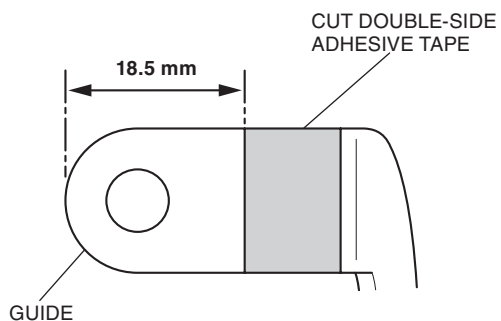

17. Remove the adhesive backing as shown.

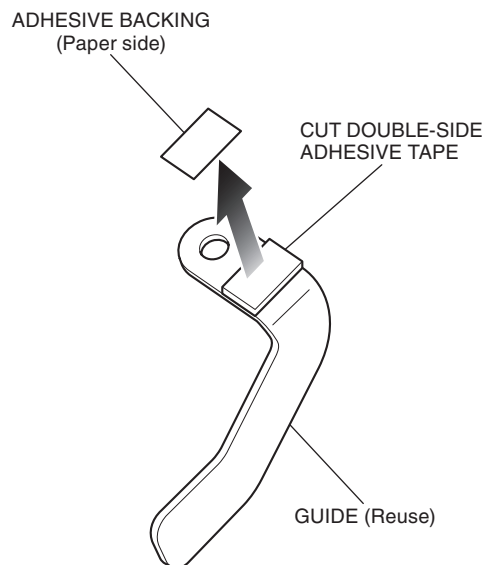

18. Install the rear fender C and guide as shown.

<Left side>

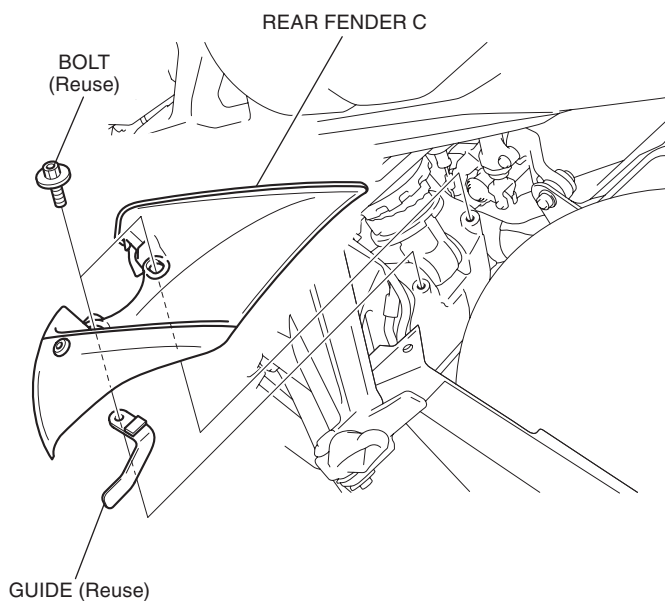

19. Install the motorcycle's parts in the reverse order of removal.